

---

# User's Manual

## for Trampolines

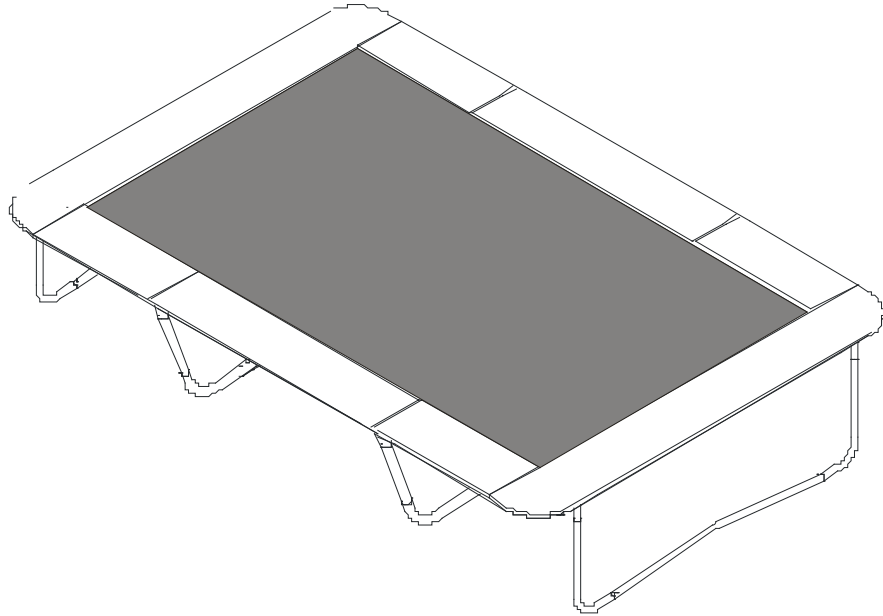

### Trampoline Specifications:

- 10ft x 15ft (TATR-1015)       10ft x 17ft (TATR-1017)

### Springs:

- 92     104

---

## INTRODUCTION

**Before you begin use of this trampoline, be sure to carefully read all the information Provided to you in this manual.** Just like any other type of physical recreational activity, Participants can be injured. To reduce the risk of injury, be sure to follow appropriate safety rules and tips.

- Misuse and abuse of this trampoline is dangerous and can cause serious injury!
- Recommended for ages 6 and up.
- This equipment should be assembled by two peoples.
- Trampoline, being rebounding devices, propel the performer to unaccustomed heights and into a variety of body movements.
- Always inspect the trampoline before each use for wear-out mat, loose or missing parts.
- Proper assembly, care and maintenance of product, safety tips, warnings, and proper Techniques in jumping and bouncing are all included in this manual. All users and Supervisors must read and familiarize themselves with these instructions. Anybody who chooses to use this trampoline must be aware of their own limitations in regards to performing various jumps and bounces with this trampoline.

---

### Warning !



NO MORE THAN ONE PERSON AT A TIME ON THE TRAMPOLINE! MULTIPLE JUMPERS INCREASE THE RISK OF INJURY SUCH AS BROKEN HEAD, NECK, LEG, OR BACK.



DO NOT PERFORM SOMERSAULTS (FLIPS AS THIS WILL INCREASE YOUR CHANCES OF LANDING ON YOUR HEAD OR NECK.

**Always consult a physician before performing any kind of physical activity.**

**PLEASE RETAIN THIS INFORMATION FOR FUTURE REFERENCE**

---

## INFORMATION ON USE OF THE TRAMPOLINE

Initially, you should get accustomed to the feel and bounce of the trampoline. The focus must be on the fundamentals of your body position and you should practice each bounce (the basic bounces) until you can do each skill with ease and control.

**To brake a bounce, all you need to do is flex your knees sharply before they come in contact with the mat of the trampoline.** This technique should be practiced while you are learning each of the basic bounces. The skill of braking should be used whenever you lose balance or control of your jump.

Always learn the simplest bounce first and be consistent with the control of your bounce before moving on to more difficult and advanced bounces. **A controlled bounce is one when your take off point and landing point is the same spot on the mat.** If you move up to the next bounce without first mastering the previous, you increase your chances of getting injured.

Do not bounce on the trampoline for extended periods of time because fatigue can increase your chances of becoming injured. Bounce for a brief period of time and then allow others to join in on the fun! Never have more than one person bouncing on the trampoline.

Jumpers should wear t-shirt, shorts or sweats, and regulation gymnastics shoes, heavy socks, or be barefoot. If you are just beginning, you may want to wear long sleeve shirts and pants to protect against scrapes and abrasions until you master correct landing positions and form. Do not wear hard sole shoes, such as tennis shoes, on the trampoline as this will cause excessive wear on the mat material.

You should always mount and dismount properly in order to avoid injury. To mount properly, you should PLACE your hand on the frame and either step or roll up onto the frame, over the springs, and onto the trampoline mat. You should always remember to place your hands onto the frame while mounting or dismounting. Do not step directly onto the frame pad or grasp the frame pad. To dismount properly, move over to the side of the trampoline and place your hand onto the frame as a support and step from the mat to the ground. Smaller children should be assisted when mounting and dismounting the trampoline.

Do not bounce recklessly on the trampoline since this will increase your chances of getting injured. The key to safety and having fun on the trampoline is control and mastering the various bounces. Never try to out-bounce another bouncer in terms of height! Never use the trampoline alone without supervision.

---

## ACCIDENT CLASSIFICATION

*Mounting and Dismounting:* Be very careful when getting on and off the trampoline. DO NOT mount the trampoline by grabbing the frame pad, stepping onto the springs, or by jumping onto the mat of the trampoline from any object (i.e. a deck, roof, or ladder). This will increase your chances of getting injured! DO NOT dismount by jumping off the trampoline and landing on the ground regardless of the makeup of the ground. If small children are playing on the trampoline, they may need help in mounting and dismounting.

*Use of Alcohol or Drugs:* DO NOT consume any alcohol or drugs when using this trampoline! This will increase your chances of getting injured since these foreign substances impairs your judgements, reaction time, and overall physical coordination

*Multiple Jumpers:* If you have multiple jumpers (more than one person on the trampoline at any one time), you increase the chance of getting injured. Injuries could occur when you fly off the trampoline, lose control, collide with the other jumper(s), or land on the springs. Generally, the lightest person on the trampoline will get injured.

*Striking the Frame or Springs:* When playing on the trampoline, STAY in the centre of the mat. This will reduce your risk of getting injured by landing on the frame or springs. Always keep the frame pad covering the frame of the trampoline. DO NOT jump or step onto the frame pad directly since it was not intended to support the weight of a person.

*Loss of Control:* DO NOT try difficult manoeuvres, or any manoeuvres until you have mastered the previous manoeuvre, or if you are just learning how to jump on a trampoline. If you do, you will increase your risk of getting injured by landing on the frame, springs, or off the trampoline completely because you might lose control of your jump. A controlled jump is considered landing on the same spot that you took off from. If you do lose control when you are jumping on the trampoline, bend your knees sharply when you land and this will allow you to regain control and stop your jump.

*Somersaults (Flips):* DO NOT PERFORM somersaults of any type (backwards or forwards) on this trampoline. If you make a mistake when trying to perform a somersault, you could land on your head or neck.. This will increase your chances of getting your neck or back broken, which will result in death or paralysis.

*Foreign Objects:* DO NOT use the trampoline if there are pets, other people, or any objects underneath the trampoline. This will increase the chances of an injury occurring. DO NOT hold any foreign objects in your hand and DO NOT place any objects on the trampoline while anyone is playing on it. Please be aware of what is overhead when you are playing on the trampoline. Tree limbs, wires, or other objects located over the trampoline will increase your chances of getting injured.

*Poor Maintenance of Trampoline:* A trampoline in poor condition will increase your risk of getting injured. Please inspect the trampoline before each use for bent steel tubes, torn mat, loose or broken springs, and overall stability of the trampoline.

---

*Weather Conditions:* Please be aware of the weather conditions when using the trampoline. If the mat of the trampoline is wet, the jumper could slip and injure him or herself. If it is too windy, jumpers could lose control.

*Limiting Access:* When the trampoline is not in use, always store the access ladder in a secure place so that unsupervised children cannot play on the trampoline.

## **TIPS TO REDUCE THE RISK ACCIDENTS**

### **Jumper's role in accident prevention**

The key here is to stay in control of your jumps. DO NOT move onto more complicated, more difficult manoeuvres until you have mastered the basic, fundamental bounce.

Education is also key to safety and very important. Read, understand, and practice all safety precautions and warnings prior to using the trampoline. A controlled jump is when you land and take off from the same location. For additional safety tips and instructions, contact a certified trampoline instructor.

### **Supervisor's Role in Accident Prevention**

Supervisors need to understand and enforce all safety rules and guidelines. It is the responsibility of the supervisor to provide knowledgeable advice and guidance to all jumpers of the trampoline. If supervision is unavailable or inadequate, the trampoline could be stored in a secure place, disassembled to prevent unauthorized use, or covered with a heavy tarpaulin that can be locked or secured with lock or chains. The supervisor is also responsible to ensure that the safety placard is placed on the trampoline and that jumpers are informed of these warnings and instructions.

---

## TRAMPOLINE SAFETY INSTRUCTIONS

### JUMPERS:

- Do not use trampoline if you have consumed alcohol or any drugs
- Remove all hard sharp objects from person before using trampoline
- You should climb on and off in a controlled and careful manner. Never jump on or off the trampoline and never use the trampoline as a device to bounce onto or into another object.
- Always learn the basic bounce and master each type of bounce before trying more difficult types of bounces. Review the Basic Skills Section to learn how to do the basics
- To stop your bounce, flex your knees when you land on the mat with your feet
- Always be in control when you are bouncing on the trampoline. A controlled jump is when you land at the same spot that you took off from. If at any time you feel out of control, try to stop your bouncing.
- Do not jump or bounce for prolonged periods of time or too high for a number of jumps
- Keep your eyes on the mat to maintain control. If you do not, you could lose balance or control
- Never have more than 1 person on the trampoline at any time
- Always have a supervisor watching you when you are on the trampoline

### SUPERVISORS

Educate yourself with the basic jumps and safety rules. To prevent and reduce the risk of injuries, enforce all safety rules and ensure that new jumpers learn the basic bounces before trying more difficult and advanced jumps

- All jumpers need to be supervised, regardless of skill level or age.
- Never use the trampoline when it is wet, damaged, dirty, or worn out. The trampoline should be inspected before any jumpers start bouncing on it.
- Keep all objects that could interfere with the jumper away from the trampoline. Be aware of what is overhead, underneath, and around the trampoline.
- To prevent unsupervised and unauthorized use, the trampoline should be secured when not in use.

---

## **TRAMPOLINE PLACEMENT**

The minimum overhead clearance required is 24 feet (7.3 meters). In terms of horizontal clearance, please ensure that no hazardous objects are near the trampoline such as tree limbs, other recreational objects (i.e. swing sets, swimming pools), electrical power wiring, walls, fences, etc.

For safe use of the trampoline, please be aware of the following when selecting a place for your trampoline:

- Make sure it is placed on a level surface
- The area is well-lighted
- There are no obstructions beneath the trampoline

If you do not follow these guidelines, you increase the risk of someone getting injured.

**⚠ WARNING!**

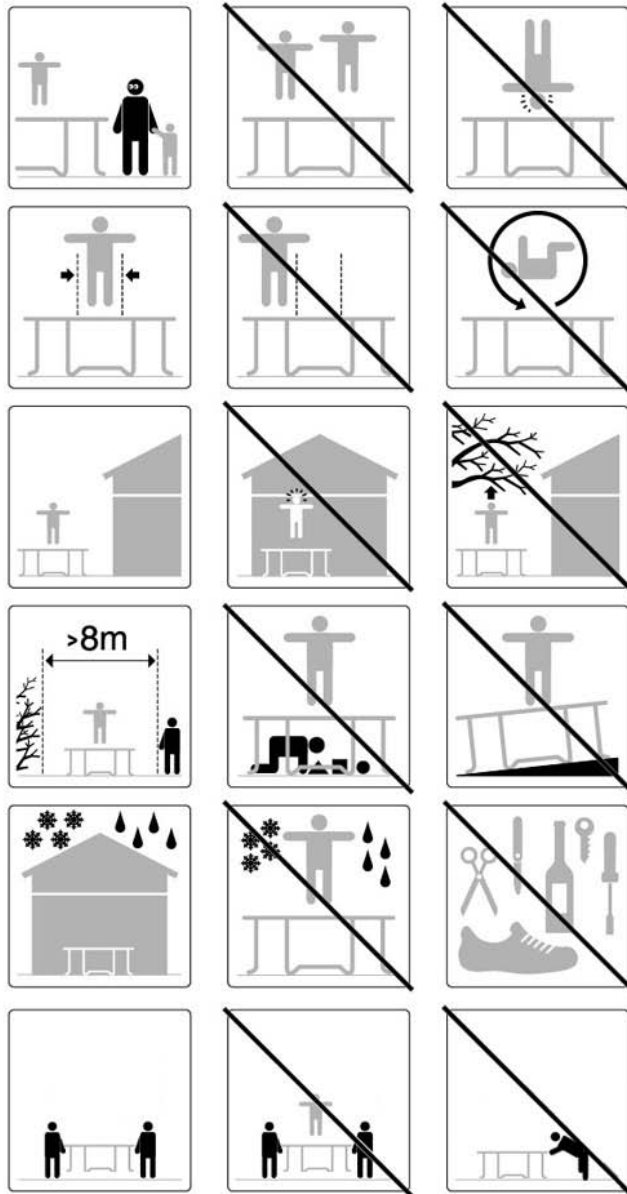

**LESSON PLAN**

The following lessons are suggested in order to learn basic steps and bounces before moving onto more difficult, complicated bounces. Before actually getting on and using the trampoline, you should read and understand all safety instructions. A complete discussion and demonstration of body mechanics and trampoline guidelines should occur between the supervisor and student as well.

**Lesson 1**

- A. Mounting and Dismounting - Demonstration of proper techniques
- B. The Basic Bounce-Demonstration and practice
- C. Braking (Check the Bounce) - Demonstration and practice. Learn to brake on command
- D. Hands and knees - Demonstration and practice. Stress should be on four- point landing and alignment

**Lesson 2**

- A. Review and practice of techniques learned in Lesson 1



- B. Knee Bounce-Demonstration and practice. Learn the basic down to knee and back up before trying half twist to left and right
- C. Seat Bounce -Demonstration and practice. Learn basic seat bounce then add a knee bounce, hands and knees; repeat

### Lesson 3

- A. Review and practice skills and techniques learned in previous lessons
- B. Front Drop-To avoid mat burns and teach the front bounce position, all students should be requested to assume the prone position(face down on the ground) while the instructor checks for faulty positions that could cause injury.
- C. Start with a hands and knees bounce and then extend body into prone position, land on the mat and return to feet
- D. Practice Routine-Hands and knees Bounce, Front Bounce, back to feet, seat bounce, back to feet

### Lesson 4

- A. Review and practice skills and techniques learned in previous lessons
- B. Half-Turn
  - i. Start from front drop position and as you make contact with the mat, push off with arms in either the right or left direction and turn head and shoulders in same direction.
  - ii. During turn, be sure to keep back parallel to mat and head up.
  - iii After completing turn, land in front drop position

After completing this lesson, the student now has a basic foundation of trampoline bounces. Jumpers should be encouraged to try and develop their own routines with the emphasis on control and form.

A game that can be played in order to encourage students to try and develop routines is "BOUNCE". In this game, players count from 1 to X. Player one starts with a maneuver. Player two has to do Player One's maneuvered and adds on another. Player Three does the maneuvers of one and Two and then adds a third maneuver. This continues until a player cannot do the routine until someone spells out the word "BOUNCE". The last remaining contestant is deemed the winner! Even when playing this game, it is important to **perform your routines under control** and not try difficult or highly skilled bounces that you have not yet mastered.

A certified trampoline instructor should be contacted to further develop your trampoline skills.

## BASIC TRAMPOLINE BOUNCES

### THE BASIC BOUNCE

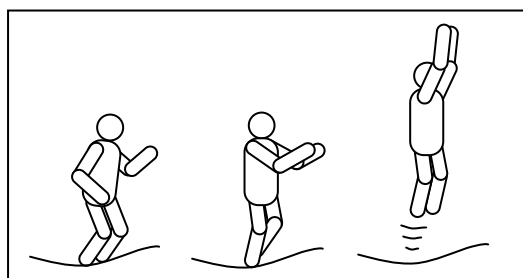

1. Start from standing position, feet shoulder width apart and with head up and eyes on mat
2. Swing arms forward and up and around in a circular motion.
3. Bring feet together while in mid-air and point toes downward
4. Keep feet shoulder width apart when landing on mat.

---

## KNEE BOUNCE

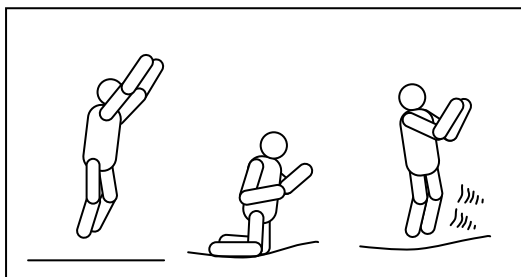

1. Start with basic bounce and keep it low
2. Land on knees keeping back straight, body erect and use your arms to maintain balance
3. Bounce back to basic bounce position by swinging arms up

## SEAT BOUNCE

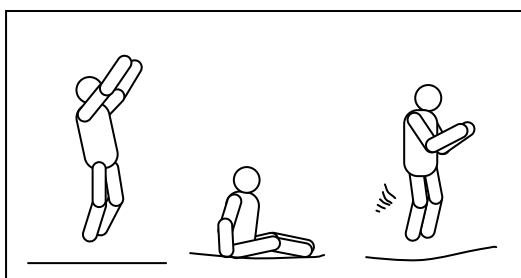

1. Land in a flat sitting position.
2. Place hands on mat besides hips
3. Return to erect position by pushing with hands.

## FRONT BOUNCE

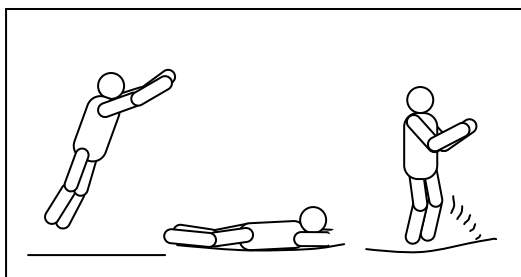

1. Start with front bounce position
2. Land in prone ( face down) position and keep hand and arms extended forward on mat
3. Push off the mat with arms to return to standing position

## 180 DEGREE BOUNCE

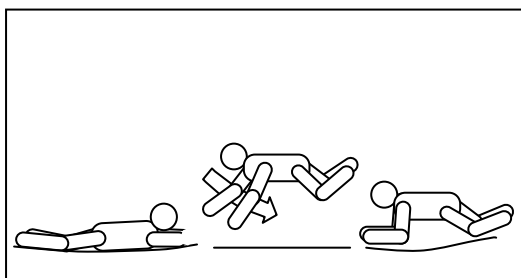

1. Start with front bounce position
2. Push off with left or right hands and arms (depending on which way you wish to turn)
3. Maintain head and shoulders in the same direction and keep back parallel to mat and head up
4. Land in prone position by return to standing position by pushing up with hands and arms

---

## ASSEMBLY INSTRUCTIONS

To assemble this trampoline all you need is our special spring loading tool provided with this product. During periods of non-use. This trampoline can be easily disassembled and stored.

**Please read the assembly instructions before beginning to assemble the product.**

### PRIOR TO ASSEMBLING

Please refer to page for part descriptions and numbers. The assembly steps use these descriptions and numbers as reference for your convenience.

Make sure that you have all parts listed. If you are missing any parts, please refer to page for Instructions on how to attain any parts.

To prevent any injuries to your hands from pinch points during assembly, **please use gloves to protect your hands.**

### PARTS LIST

Please select your trampoline size.

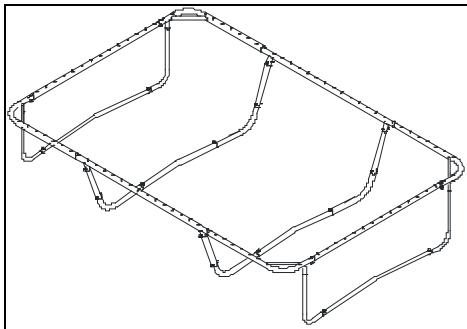

10ft x 15ft (TATR-1015)

*This model rectangular trampoline without support steel plates under the Middle Legs.*

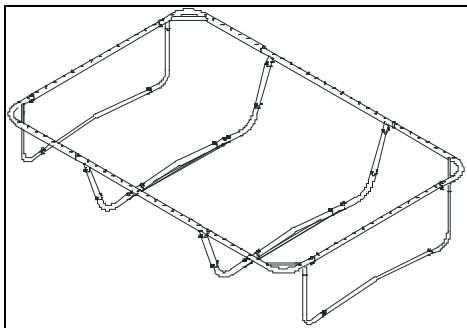

10ft x 17ft (TATR-1017)

This model rectangular trampoline have 2 support steel plates under the Middle Legs.

**Q'TY**

<b>ITEM</b>	<b>DESCRIPTION</b>	<b>TATR-1015</b>	<b>TATR-1017</b>
1	L Shape Leg for Middle Bar	4	4
2	Connect Bar for Middle Leg	2	2
3	Support Steel Plate	N/A	2
4	Leg Extension for Middle Leg	4	4
5	Side Bar	2	2
6	L Shape Corner Bar A	2	2
7	L Shape Corner Bar B	2	2
8	End bar	2	2
9	Leg Extension for End Leg	4	4
10	Connect Bar for End Leg	2	2
11	Jumping Mat	1	1
12	Springs	92	104
13	Short Pad for End Bar	2	2
14	Long Pad for Side Bar	2	2
15	Bungee Cord	18	18
H1	M8x80 Socket Button Head Screw	20	20
H2	8mm Washer	48	64
H3	M8 Nylon Lock Nut	24	32
H4	M8 Plastic Acorn Nut	24	32
H5	M8x85 Socket Button Head Screw	N/A	8
H6	M8x60 Socket Button Head Screw	4	4

REMEMBER TO USE GLOVES DURING ASSEMBLY TO AVOID PINCHING and IT WILL TAKE AT LEAST TWO PEOPLE TO ASSEMBLE THE TRAMPOLINE

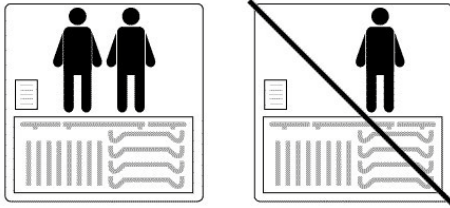

**Assembly for TATR-1015, TATR-1017**

Note: We recommend at least 2 people participate in assembling the trampoline.

1. Attach the “L” Shape Leg for Middle Leg (1) to Connect Bar for Middle Leg (2), and connect them by M8x80mm Socket Button Head Screw (H1). This step use following parts:

Item	Description	Q'ty
1	“L” Shape Leg for Middle Leg	4
2	Connect Bar for Middle Leg	2
H1	M8x80 Socket Button Head Screw	4
H2	8mm Washer	8
H3	M8 Nylon Lock Nut	4
H4	M8 Plastic Acorn Nut	4

Please do not tighten all of the screws.

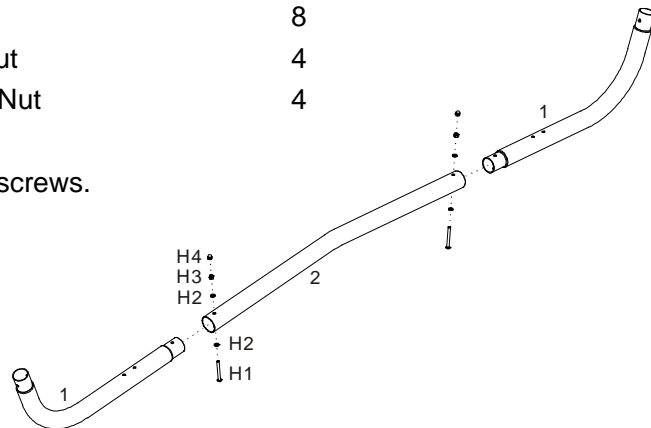
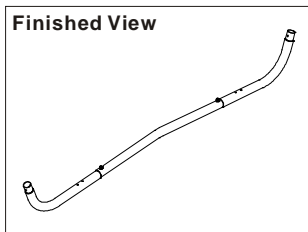

Note:

This rectangular trampoline use 3 kinds of screws assembly:  
 M8x60 Screw Assembly    M8x80 Screw Assembly    M8x85 Screw Assembly  
 Please refer Screw List.

Each Screw assembly included a M8 screw, 2pcs 8mm washers, a M8 Nylon Lock nut and a M8 Plastic Acorn Nut.

Please refer Screw assembled.

**Screw List**

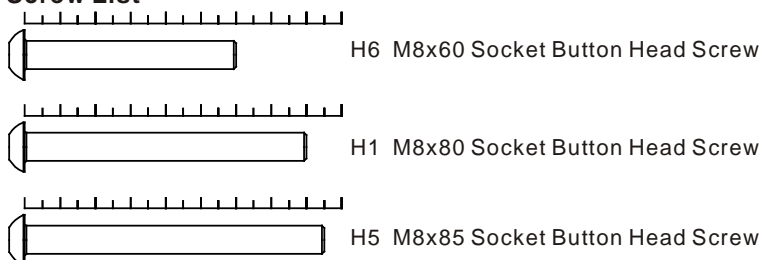

**Screw Assembled**

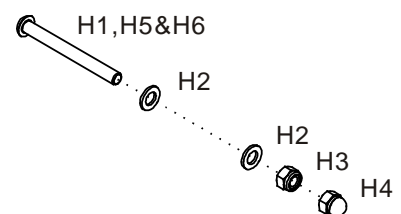

2. Attach the Leg Extension for Middle Leg (4) to “L” Shape Leg for Middle Leg (1), and connect them by M8x80mm Socket Button Head Screw (H1).

3. Attach Connect Support Steel Plate (3) to “L” Shape Leg for Middle Leg (1), and connect these 3 parts by M8x85 Socket Button Head Screw assembly (H5, H2, H3 & H4)

\* This step just for 10ft X 17ft rectangular trampoline assembling.

Item	Description	Q'ty
3	Support Steel Plate	2
4	Leg Extension for Middle Leg	4
H1	M8x80 Socket Button Head Screw	4
H2	8mm Washer	24
H3	M8 Nylon Lock Nut	12
H4	M8 Plastic Acorn Nut	12
H5	M8x85 Socket Button Head Screw	8

Please do not tighten the screws.

Repeat step 1, 2 and 3 for another middle leg.

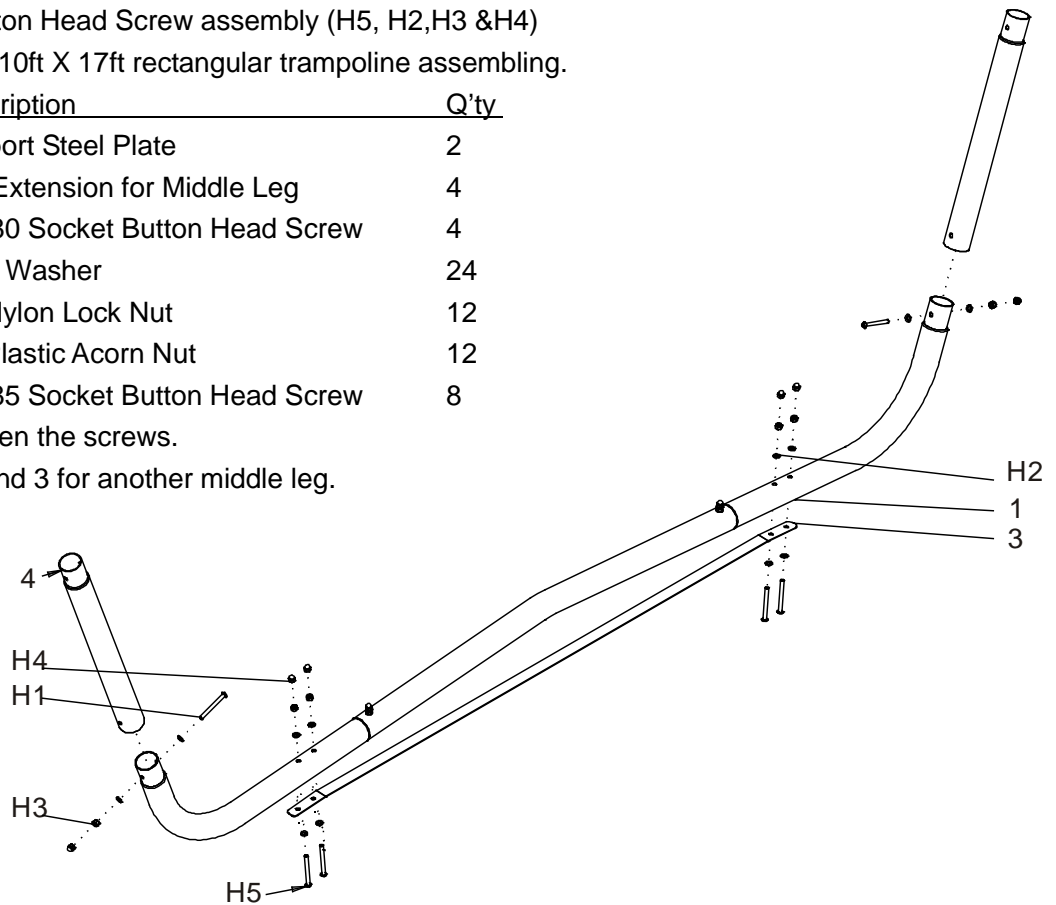

4. Attach 2 Side Bars (5) to the Leg Extension for Middle Leg (4) swage side, and tighten them by M8x80 Socket Button Head Screw Assembly (including H1, H2, H3 & H4).

Item	Description	Q'ty
5	Side Bar	2
H1	M8x80 Socket Button Head Screw	4
H2	8mm Washer	8
H3	M8 Nylon Lock Nut	4
H4	M8 Plastic Acorn Nut	4

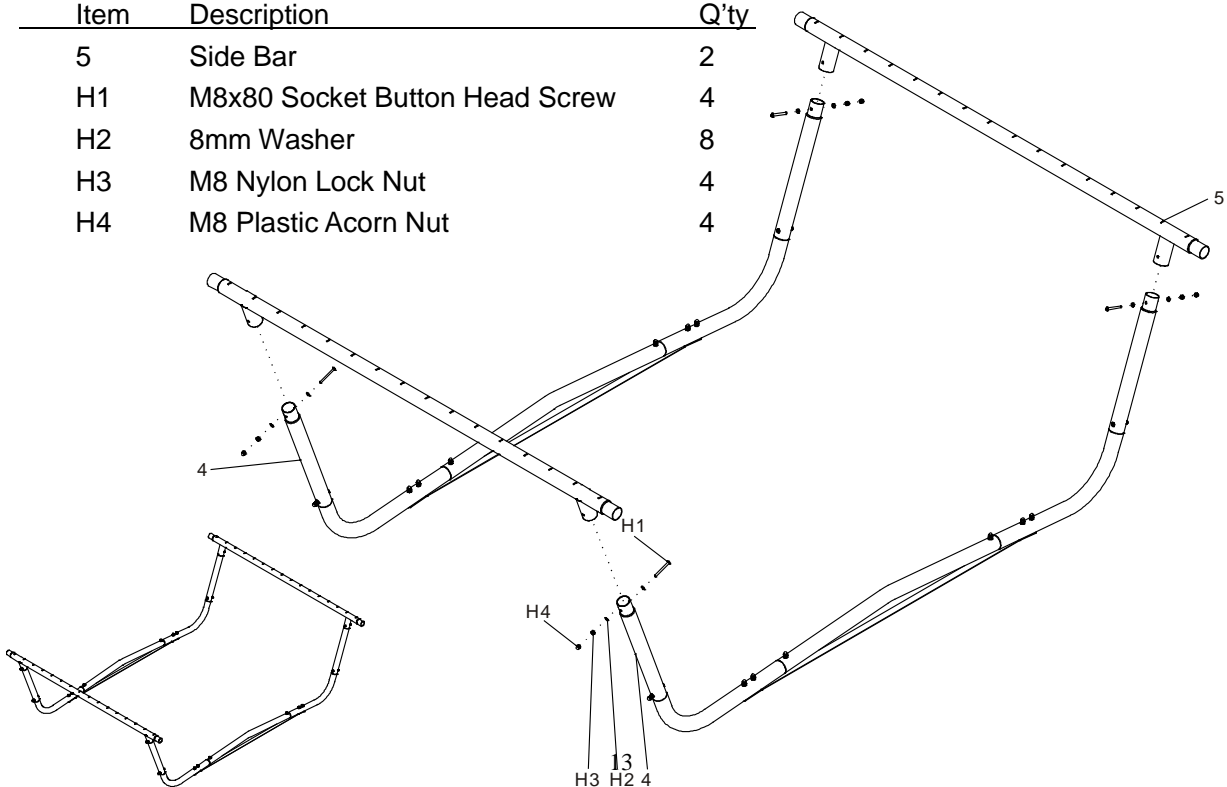

## Assembly and Installation Instructions

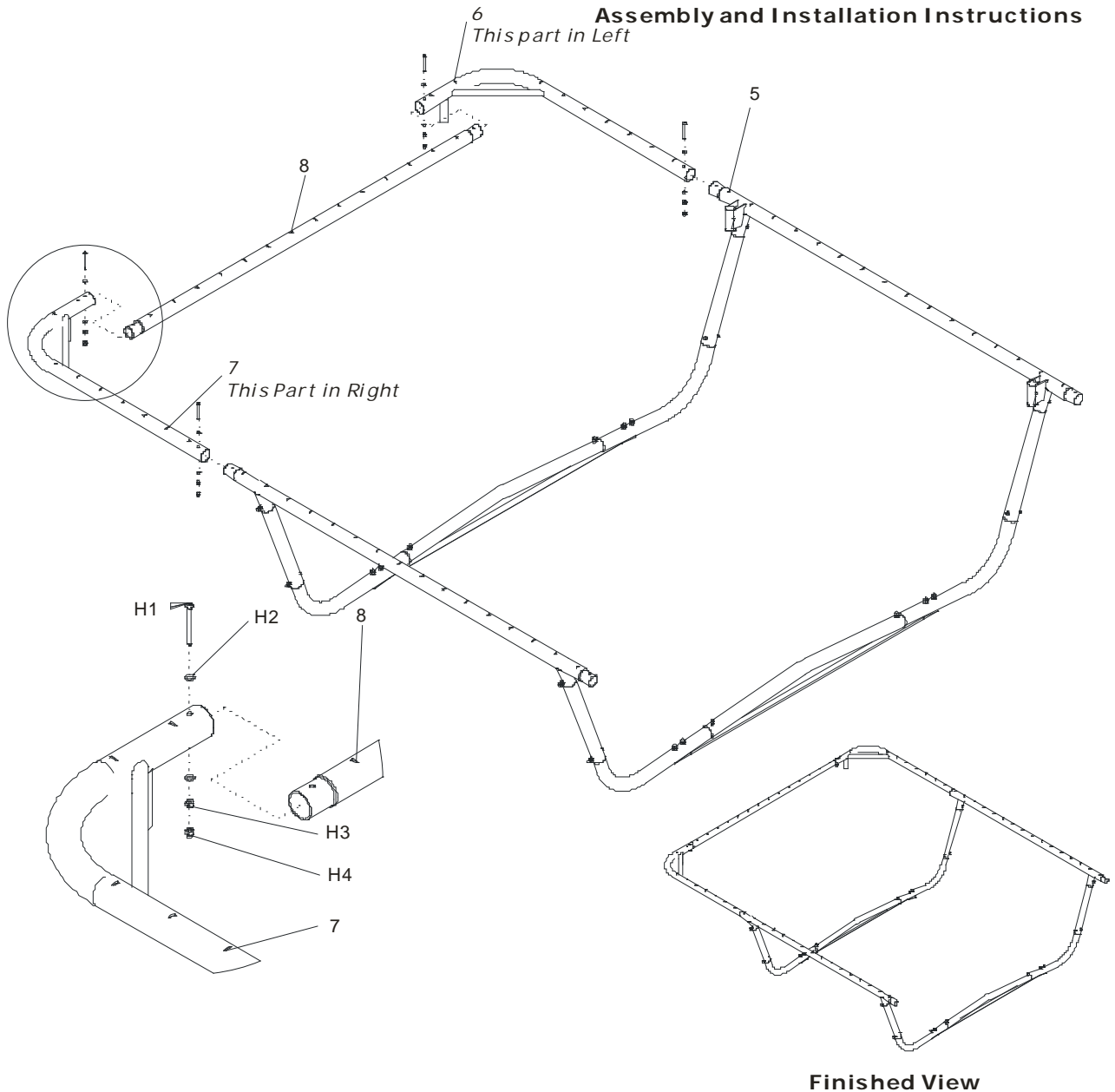

5. Attach 2 L Shape Corner Bars (6,7) to the End Bar (8) both side, and tighten by M8x80 Socket Button Head Screw Assembly (including H1, H2, H3&H4).

Item	Description	Q'ty
6	L Shape Corner Bar A	2
7	L Shape Corner Bar B	2
8	End Bar	2
H1	M8x80 Socket Button Head Screw	8
H2	8mm Washer	16
H3	M8 Nylon Lock Nut	8
H4	M8 Plastic Acorn Nut	8

Note: The "L" Shape Corner Bars have 2 mirror directions, one in right hand and one in left. Please see assemble picture on the top.

6. Repeat step 5 for another side. Please refer the picture as shown.

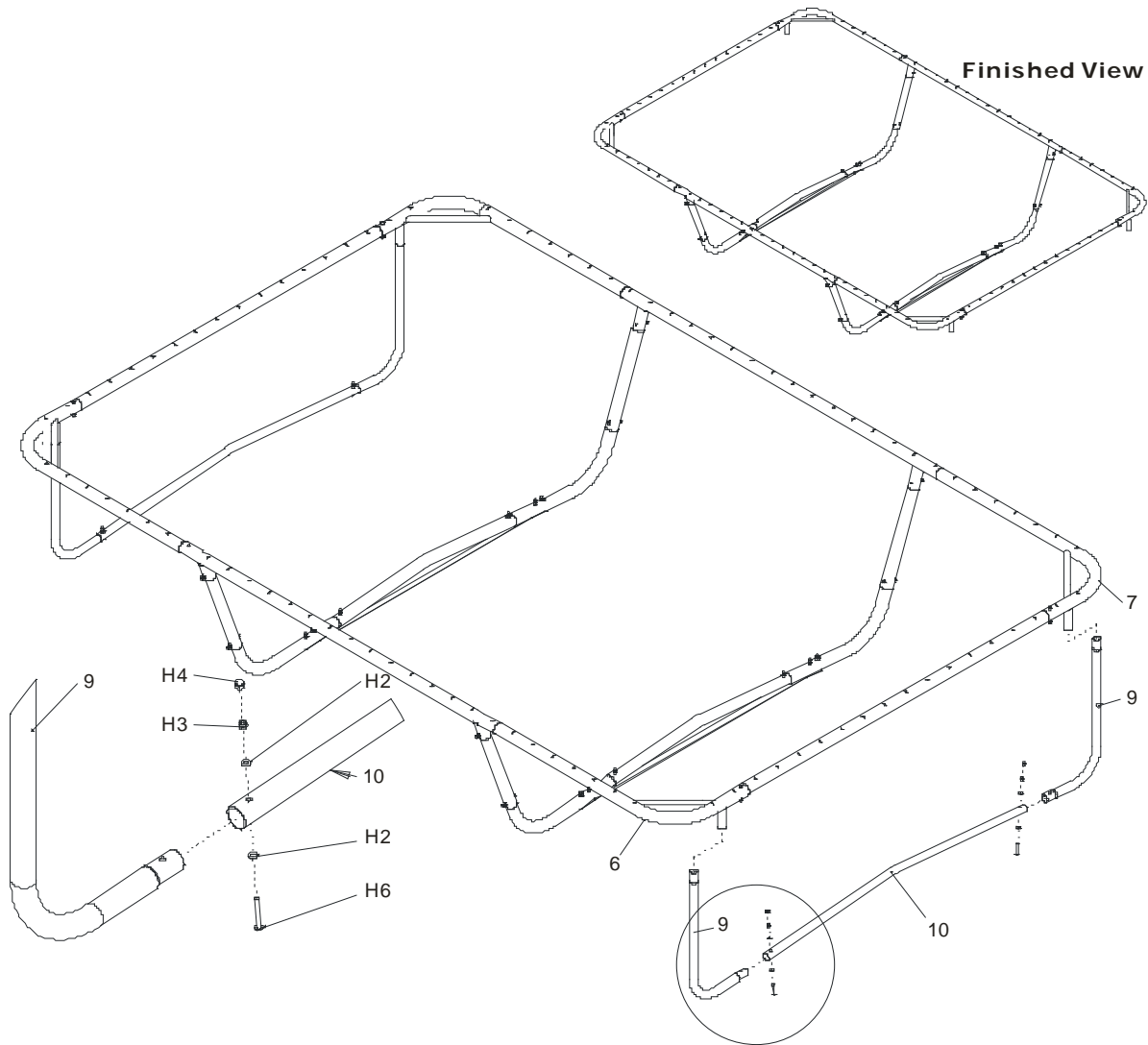

7. Insert Leg Extension for End Leg (9) swage side into the both end of the Connect Bar for End Leg (10), and tighten by M8x60 Socket Button Head Screw (H6) Assembly (H6, H2, H3&H4)

8. Insert Side Leg Assembly to the welded Socket into the “L” Shape Corner Bar (6, 7) and tighten by M8X60 Socket Button Head Screw (H6) assembly (H6, H2, H3&H4) if not use enclosure.

Item	Description	Q'ty
9	Leg Extension for End Leg	4
10	Connect Bar for End Leg	2
H6	M8x60 Socket Button Head Screw	4
H2	8mm Washer	8
H3	M8 Nylon Lock Nut	4
H4	M8 Plastic Acorn Nut	4

**Finished View**

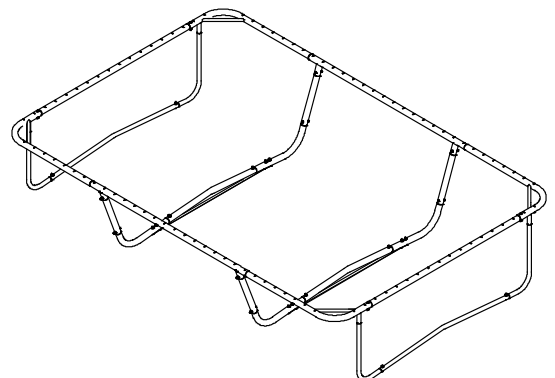

Note: Please fully tighten all bolts this time.



9. Connect Jumping Mat (11) to trampoline frame by attaches a spring to the two V-rings closest to each corner. Warning label on mat must face up.

Note: For easy spring installation, use a Special spring tool to hook onto the one you are installing.

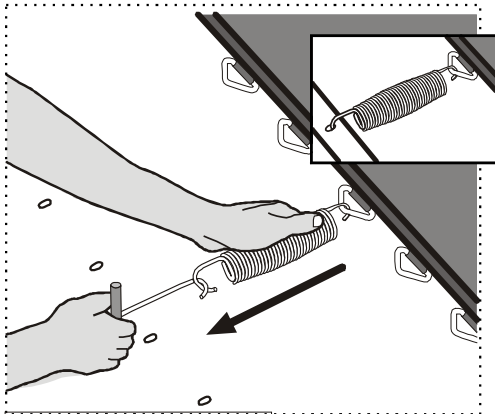

**CAUTION**  
 Pinch point.  
 Pay careful attention to hand position when connecting tubes and handling springs.

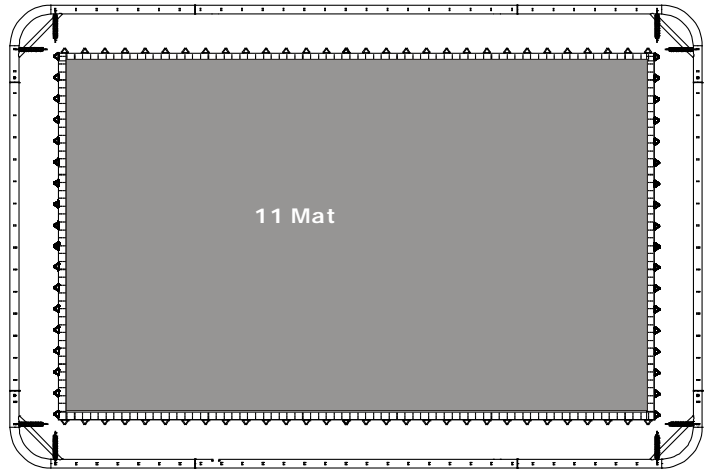
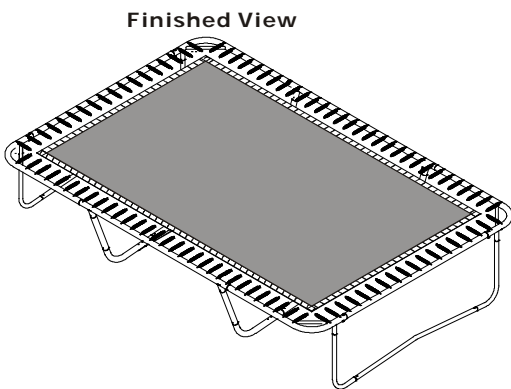

Note: It is important to have someone work across from you. Otherwise the springs could become over-extended, causing them to become difficult to connect.

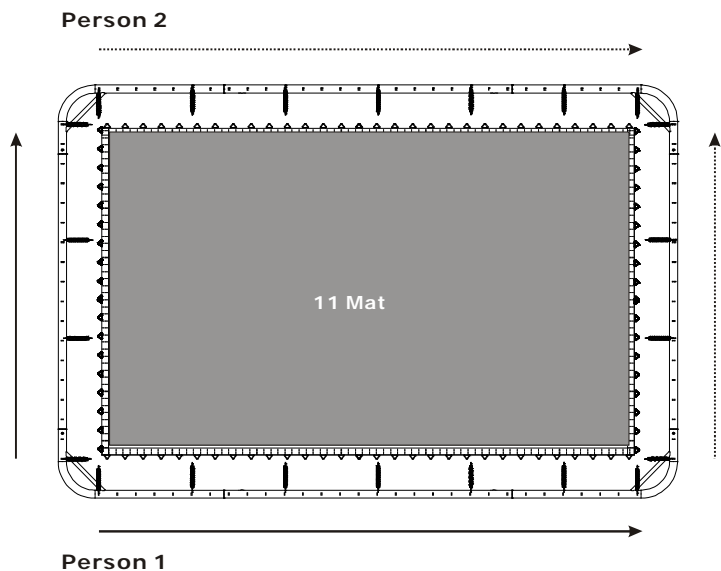

Item	Description	Q'ty
11	Jumping Mat	1
* 12	Springs	92 or 104

Note:

Please checking your trampoline specification which shown in main page, make sure you have correct spring quantity.

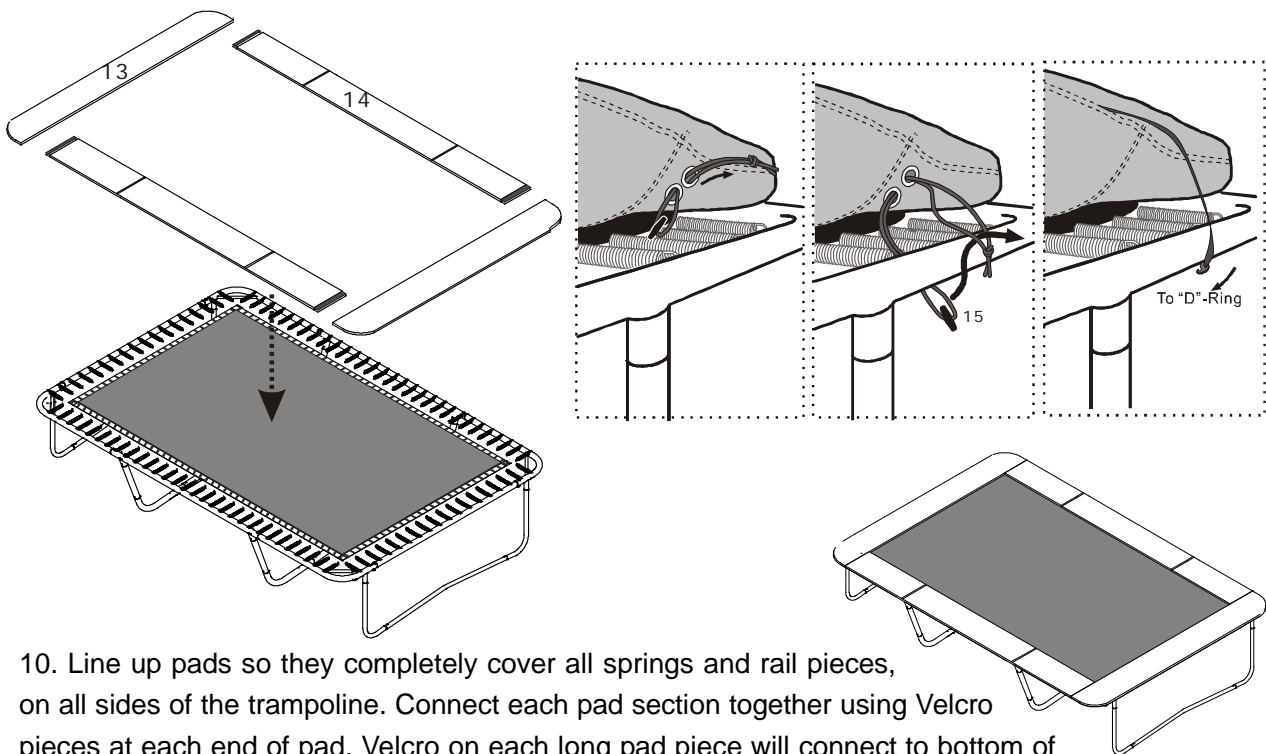

10. Line up pads so they completely cover all springs and rail pieces, on all sides of the trampoline. Connect each pad section together using Velcro pieces at each end of pad. Velcro on each long pad piece will connect to bottom of each short pad piece.

11. Install pad bungee Cord onto bottom side of pad, as shown.

*Note: Do not use pad Bungee Cord to secure frame pad around leg of trampoline at this time. This will be done after installing the safety enclosure poles in a later step.*

<i>Item</i>	<i>Description</i>	<i>Q'ty</i>
13	Short Pad for End Bar	2
14	Long Pad for Side Bar	2
15	Bungee Cord	18

**WARNING:**

*Trampoline use is not recommended without the frame pad installed. The frame pad is designed to reduce the possibility of injury by protecting the user from coming into contact with the frame and springs of the trampoline. It is very important that you properly and securely attach the frame pad to the frame, and that it is in the correct position prior to using the trampoline.*